



德昌产品介绍



August 13,2008

<p>LOW POWER SMDs</p>	     <p>MELF SOD87 Mini-MELF SOD80C SOD123/323/523</p>
<p>LOW & HIGH POWER AXIALs</p>	          <p>AXIAL PRESS FIT TO-220 TO-220F DO-41P DO-15 DO-201AD DO-41 DO-35 DO-34</p>
<p>HIGH POWER SMDs</p>	     <p>JUMBO SSTM MICRO TOPCAN CELL</p>



Package	Family	Device
SOD-123 	Switching	1N4148W, 1N4448W, 1N914BW
		BAV19W, BAV20W, BAV21W
	Schottky	BAT42W, BAT43W, BAT54W
	Zener	MMSZ2V4B~MMSZ75VB
		MMSZ2V4C~MMSZ75VC
		MMSZ5221BW~MMSZ5263BW
	SOD-323 	Switching
1SS355		
BAV19WS, BAV20WS, BAV21WS		
Schottky		RB551V-30, RB500V-40, RB501V-40, RB751V-40
		BAT42WS, BAT43WS, BAT54WS
Zener		MM3Z2V4B~MM3Z75VB
		MM3Z2V4C~MM3Z75VC
		UDZS2V0B~UDZS36VB
		MMSZ5221BSW~MMSZ5263BSW
SOD-523 		Switching
	1SS400	
	BAS16	
	Schottky	RB520S-30, RB521S-30, TB520S-40, RB521S-40, RB751S-40
		BAT42XV2, BAT43XV2, BAT54XV2
	Zener	MM5Z2V4~MM5Z75V
		BZX584C2V4~BZX584C75V





August 13,2008



PKG	Family	Device
LS-34 	Switching	TCLS4148
		TCLS4448
		TCLS914B
	Zener	TCBZT55C2V0~TCBZT55C56
LL-34 	Switching	TCLL4148, TCLL4448, TCLL4151, TCLL914B
		TCBAV100, TCBAV101, TCBAV102, TCBAV103
	Zener	TCLZ2V2~TCLZ39
		TCLZJ2V0~TCLZJ39V
		TCLLZ2V0~TCLLZ56V
		TCZM2V4B/C~TCZM75B/C
		TCLLZ5221B~TCLLZ5263B
		TCBZV55C2V0~TCBZV55C56
	Schottky	TCBZV79C2V0~TCBZV79C56
		TCLL5711, TCLL6263
		TCLL101A, TCLL101B, TCLL101C
Trigger	LLDB3	
LL-41 	Zener	TCZM4728A~TCZM4758A

PKG	Family	Device
DO-34 	Switching	TC1N4148M, TC1N4448M, TC1N914BM
		TC1SS133M, TC1SS244M
	Zener	TCMZ2V0~TCMZ75V
		TCMTZJ2V0~TCMTZJ39V
DO-35 	Switching	TC1N4148, TC1N4448, TC1N914B
		TCBAV19,TCBAV20,TCBAV21,TCBAW76
	Zener	TC2V0~TC56V,TCZL2V4~TCZL75
		TCZX2V0~TCZX39V
		TC1N957B~TC1N979B
		TC1N4370A~TC1N4372A
		TC1N746A~TC1N759A
		TC1N5221B~TC1N5263B
		TC1N5985B~TC1N6018B
		TCBZX55C2V0~TCBZX55C75
		TCBZX79C2V0~TCBZX79C75
		Schottky
	TCBAT42, TCBAT43, TCBAT85	
	Trigger	DB3
Tuner AFC	FV-1043	
DO-41G 	Zener	TC1N4728A~TC1N4758A
		TCBZX85C3V3~TCBZX85C56

**TC-ON
Products**

PKG	Family	Device
DO-35 (TC-ON) 	Zener	1N957B~1N992B
		1N4370A~1N759A
		1N4678~1N4717
		1N5221B~1N5281B
		1N5985B~1N6025B
		BZX55C2V4~BZX55C91
		BZX79C2V4~BZX79C200
		MZ4614~MZ4104
	Zener	1N4728A~1N4764A
		BZX85C3V3~BZX85C100

PKG	Family	Device
Press Fit 	Automotive Rectifiers	TCPF2501~TCPF2510
Button 	Automotive Rectifiers	TCPF2501~TCPF2510
TO-220 	Schottky	TCMBR2060, TCMBR2060CT
		TCMBR10100CT~TCMBR10200CT
		TCMBR20100CT~TCMBR20200CT
	MOSFET	IRF730, IRF740
		IRF830, IRF840
		TFP2N60, TFP4N60
		TFP7N60, TFP8N60
TO-220F 	Schottky	TCMBRF2060, TCMBRF2060CT
		TCMBRF10100CT~TCMBRF10200CT
		TCMBRF20100CT~TCMBRF20200CT
	MOSFET	TFF2N60, TFF4N60
		TFF7N60, TFF8N60

PKG	Family	Device
DO-41 	Schottky	SB120~SB1100
		1N5817~1N5819
	General Purpose Rectifiers	1N4001~1N4007
	Fast Recovery Rectifiers	FR101~FR107
		1N4933~1N4937
	Ultrafast Recovery Rectifiers	UF4001~UF4007
High Efficiency Rectifiers	HER101~HER108	
DO-15 	Schottky	SB220~SB2100
	General Purpose Rectifiers	1N5393~1N5399
	Fast Recovery Rectifiers	FR201~FR207
	Ultrafast Recovery Rectifiers	UF1501~UF1507
	High Efficiency Rectifiers	HER201~HER208
DO-201AD 	Schottky	SB320~SB3100
		SB520~SB5100
	General Purpose Rectifiers	1N5400~1N5408
		1N5821~1N5822
	Fast Recovery Rectifiers	FR301~FR307
	Ultrafast Recovery Rectifiers	UF5400~UF5408
High Efficiency Rectifiers	HER301~HER308	

August 13,2008

Flat Lead SOD-123 Package Outline

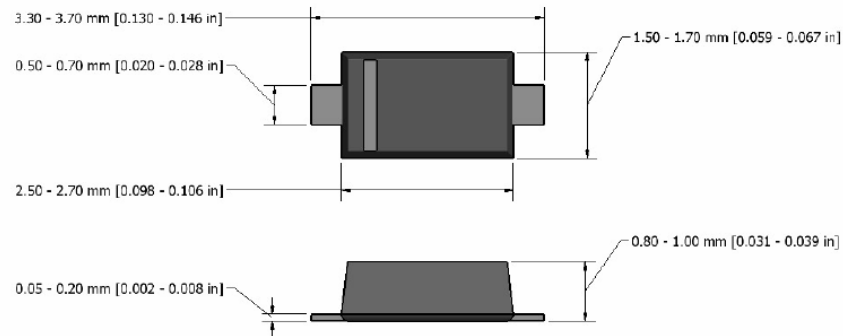

SOD-323 Package Outline

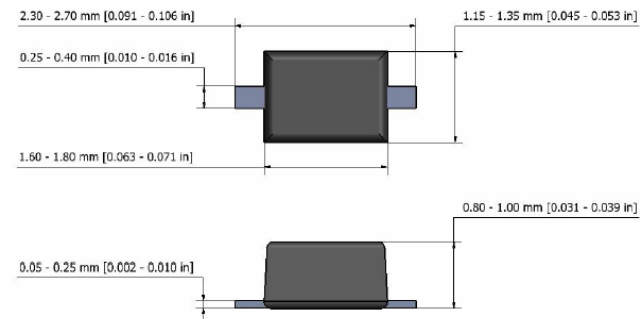

NOTE: The above package outline is similar to JEITA SC-90.

Flat Lead SOD-523 Package Outline

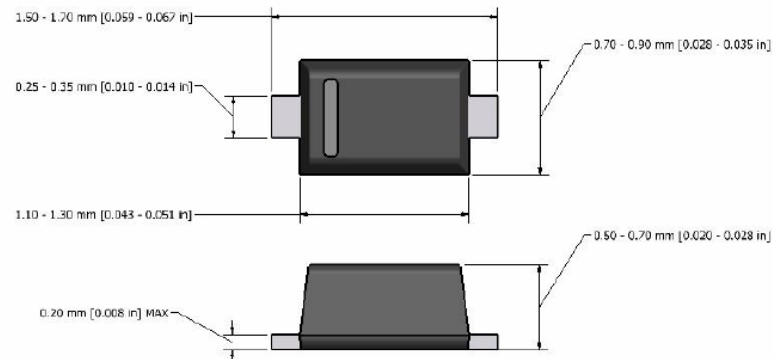

August 13, 2008

外观尺寸

Package Outline

LS-34

Case Outline

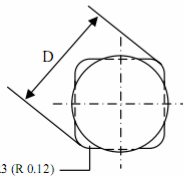
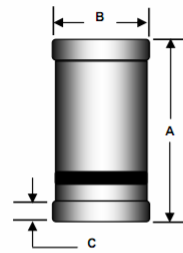

DIM	QUADRO (Mini-MELF)			
	Millimeters		Inches	
	Min	Max	Min	Max
A	3.30	3.70	0.130	0.146
B	1.40	1.60	0.055	0.063
C	0.25	0.40	0.010	0.016
D	Typical 1.8		Typical 0.071	

Package Outline

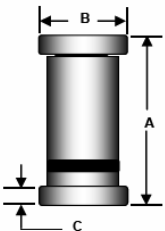
Package	Case Outline				
LL34		LL-34			
		Millimeters		Inches	
		Min	Max	Min	Max
	A	3.302	3.505	0.130	0.138
	B	1.397	1.499	0.055	0.059
	C	0.350	0.500	0.014	0.020

Package Outline

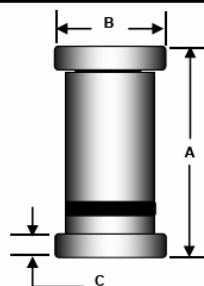
Package	Case Outline				
LL-41 MELF		LL-41 MELF			
		Millimeters		Inches	
		Min	Max	Min	Max
	A	4.80	5.20	0.189	0.205
	B	2.39	2.66	0.094	0.105
	C	0.41	0.55	0.016	0.022

August 13,2008

外观尺寸

Package Outline

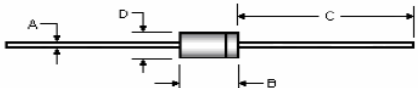
Package	Case Outline				
DO-34					
	DIM	Millimeters		Inches	
		Min	Max	Min	Max
	A	0.46	0.55	0.018	0.022
	B	2.16	3.04	0.085	0.120
	C	25.40	38.10	1.000	1.500
D	1.27	1.90	0.050	0.075	

Package Outline

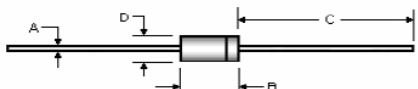
Package	Case Outline				
DO-41					
	DIM	Millimeters		Inches	
		Min	Max	Min	Max
	A	0.72	0.86	0.028	0.034
	B	4.07	5.20	0.160	0.205
	C	25.40	—	1.000	—
D	2.04	2.71	0.080	0.107	

Package Outline

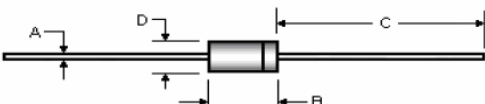
Package	Case Outline				
DO-35					
	DIM	Millimeters		Inches	
		Min	Max	Min	Max
	A	0.46	0.55	0.018	0.022
	B	3.05	5.08	0.120	0.200
	C	25.40	38.10	1.000	1.500
D	1.53	2.28	0.060	0.090	

August 13, 2008

外观尺寸

TC-ON Products

Package Outline

Case Outline

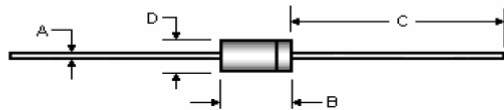

DIM	DO-35			
	Millimeters		Inches	
	Min	Max	Min	Max
A	0.46	0.56	0.018	0.022
B	3.05	5.08	0.120	0.200
C	25.40	38.10	1.000	1.500
D	1.52	2.29	0.060	0.090

Package Outline

Case Outline

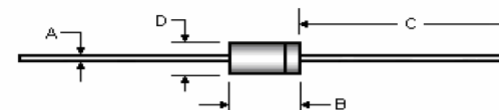

DIM	DO-41			
	Millimeters		Inches	
	Min	Max	Min	Max
A	0.72	0.86	0.028	0.034
B	4.07	5.20	0.160	0.205
C	25.40	—	1.000	—
D	2.04	2.71	0.080	0.107

August 13,2008

外观尺寸

TO220 PACKAGE OUTLINE

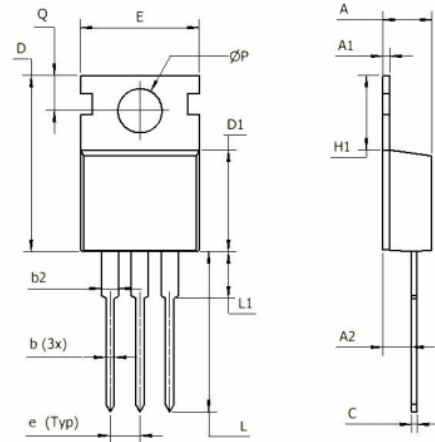

DIM	INCHES		MILLIMETERS	
	MIN	MAX	MIN	MAX
A	0.140	0.190	3.56	4.83
A1	0.020	0.055	0.51	1.40
A2	0.080	0.115	2.03	2.92
b	0.015	0.040	0.38	1.02
b2	0.045	0.070	1.14	1.78
c	0.014	0.024	0.36	0.61
D	0.560	0.650	14.22	16.51
e	0.096	0.104	2.44	2.64
E	0.380	0.420	9.65	10.67
H1	0.230	0.270	5.84	6.86
L	0.500	0.580	12.70	14.73
L1	---	0.250	---	6.35
ØP	0.139	0.161	3.53	4.09
Q	0.100	0.135	2.54	3.43

NOTE: Above package outline conforms to JEDEC TO-220AB.

TO220FP SG PACKAGE OUTLINE

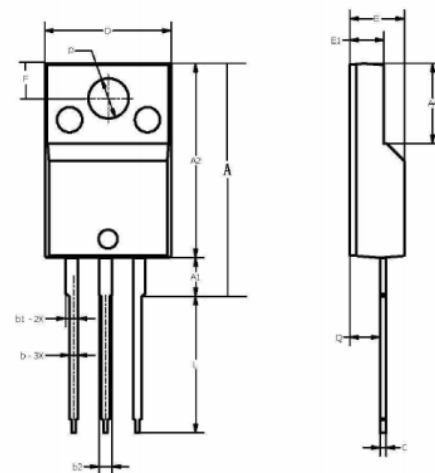

DATA VARIATION (mm)			
CODE	MIN	NOM	MAX
D	9.88	10.08	10.28
E	4.35		4.55
E1	2.53	2.73	2.93
A	18.30	18.50	18.70
A1		3.00	
A2	15.30	15.90	15.70
A4	6.20	6.40	6.60
b	0.50	0.70	0.90
b1	0.95		1.20
b2	0.95		1.20
c	0.405	0.505	0.605
e		2.54	
P	3.00	3.20	3.40
Q	2.30	2.50	2.70
F	2.60	2.80	3.00
L	10.30	10.50	10.70

NOTE: Above package outline conforms to JEDEC TO-220FP.

August 13,2008

外观尺寸

Package Outline

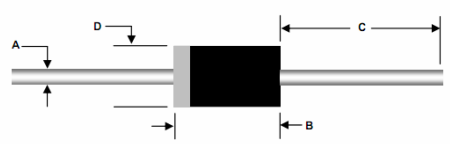
Package	Case Outline				
DO-41					
	DO-41				
	DIM	Millimeters		Inches	
		Min	Max	Min	Max
	A	0.69	0.90	0.027	0.034
	B	4.20	5.20	0.166	0.205
C	25.40	---	1.000	---	
D	2.00	2.70	0.080	0.107	

Package Outline

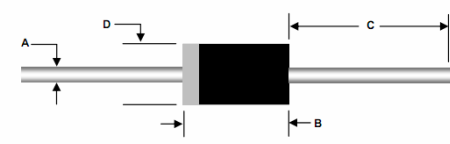
Package	Case Outline				
DO-15					
	DO-15				
	DIM	Millimeters		Inches	
		Min	Max	Min	Max
	A	0.70	0.90	0.028	0.034
	B	5.80	7.60	0.230	0.300
C	25.40	---	1.000	---	
D	2.60	3.60	0.104	0.140	

Package Outline

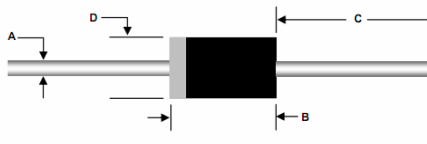
Package	Case Outline				
DO-201AD					
	DO-201AD				
	DIM	Millimeters		Inches	
		Min	Max	Min	Max
	A	1.19	1.30	0.046	0.052
	B	7.20	9.60	0.285	0.375
C	25.40	---	1.000	---	
D	4.80	5.30	0.190	0.210	

August 13,2008

外观尺寸

贴片产品包装信息

产品	数量/卷	数量/中介盒	数量/外箱	最少包装数量
SOD-123	3,000	18,000	108,000	18,000
SOD-323	3,000	18,000	108,000	18,000
SOD-523	3,000	18,000	108,000	18,000
TO-220/TO-220F	50 (管)	1,500	3,000	1,500
LL-34/LS-34	2,500 (7寸)	15,000	90,000	2,500
LL-34/LS-34	10,000 (13寸)	/	20,000	20,000
LL-41	5,000 (13寸)	/	10,000	10,000

轴型产品包装信息

		卷装		带装		散装		
		卷轮	外箱	中介盒	外箱	袋子	中介盒	外箱
DO-34/DO-35	TC/中性/KEL系列开关管	10,000	50,000	10,000	100,000	1,000	10,000	50,000
	TC/中性/KEL系列稳压管 /肖特基/触发管	10,000	50,000	5,000	100,000	500	10,000	50,000
	TC系列26mm开关管/稳压 管/肖特基/触发管	/	/	5,000	50,000	/	/	/
	K唛开关管	/	/	/	/	1,000	10,000	100,000
	K唛中性稳压管							
	FV1043变容管	/	/	/	/	1,000	10,000	50,000
DO-41	TC/中性系列稳压管	5,000	25,000	3,000	60,000	500	5,000	25,000
	K唛中性稳压管	/	/	/	/	500	10,000	50,000
DO-41 (P)	TC标准	/	/	2,500	50,000	/	1,000	50,000
DO-15		/	/	1,750	35,000	/	500	25,000
DO-27		/	/	750	15,000	/	200	10,000
DO-41 (P)		DEC/AUK/DIOTECH中性	/	/	3,000	45,000	/	/

That's All, thanks!

August 13,2008