

# MB3307

## CONSTANT VOLTAGE AND CONSTANT CURRENT CONTROLLER



**CBC Microelectronics**  
<http://www.cbcv.net>

### General Description

The MB3307 is a highly integrated solution for a constant voltage/constant current mode SMPS application.

The MB3307 contains one 1.21V voltage reference with  $\pm 1.0\%$  accuracy, one current sensing circuit and two operational amplifiers. Combining the voltage reference with one operational amplifier makes MB3307 an ideal voltage controller for use in adapters and battery chargers. The other low voltage reference combined with the other operational amplifier makes it an ideal current limiter for output low side current sensing.

The MB3307 is available in SOT-23-6 package.



SOT-23-6

Figure 1: Package Type of MB3307

### Features

- Constant Voltage and Constant Current Control.
- Precision Internal Voltage Reference.
- Few External Components.
- Easy Compensation.
- Low Supply Current: 0.5mA.
- Operating Temperature Range: -40 to 105°C

### Applications

- Adapters.
- Battery Chargers

### Pin Configuration

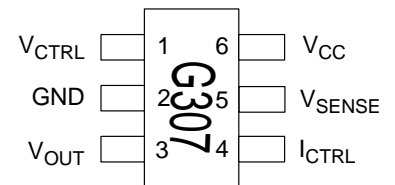
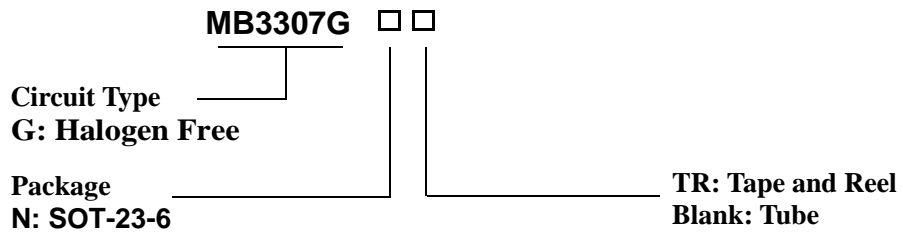

Figure 2: Pin Configuration of MB3307 (Top View)

# MB3307

## Ordering Information



Package	Temperature Range	Part Number	Marking ID	Packing Type
SOT-23-6	-40 to 105°C	MB3307GNTR	G307	Tape & Reel

## Typical Application

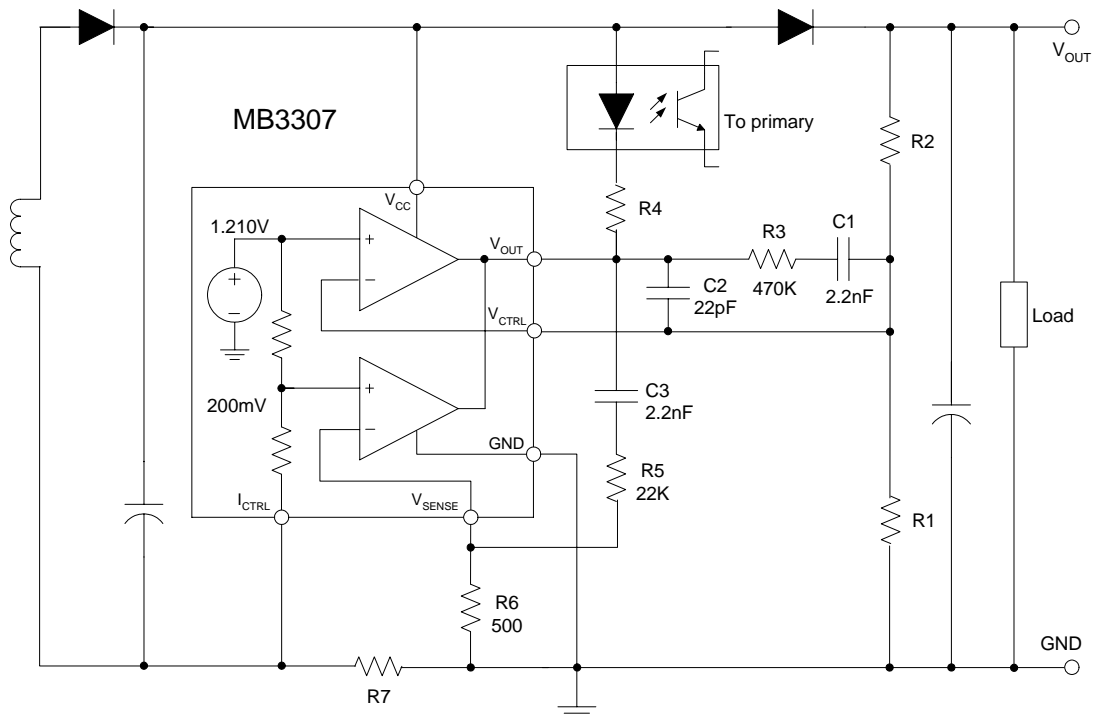

Figure3: Typical Application of MB3307

# MB3307

## Functional Block Diagram

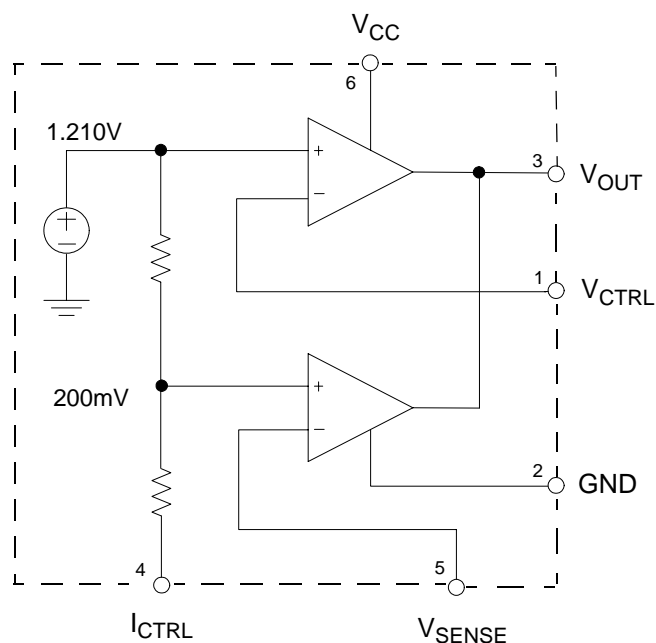

Figure4: Functional diagram of MB3307

### Absolute Maximum Ratings (Note 1)

Parameter	Symbol	Value	Unit
Power Supply Voltage	VCC	20	V
Input Voltage	V <sub>IN</sub>	-0.3 to VCC	V
Junction Temperature	T <sub>J</sub>	150	°C
Storage Temperature	T <sub>STG</sub>	-65 to 150	°C
Lead Temperature (Soldering, 5sec)	T <sub>LEAD</sub>	260	°C
Package Thermal Resistance (Junction to Case)	R <sub>θJC</sub>	92	°C/W

Note 1: Stresses greater than those listed under "Absolute Maximum Ratings" may cause permanent damage to the device. These are stress ratings only, and functional operation of the device at these or any other conditions beyond those indicated under "Recommended Operating Conditions" is not implied. Exposure to "Absolute Maximum Ratings" for extended periods may affect device reliability.

# MB3307

## Recommended Operating Conditions

Parameter	Symbol	Min	Max	Unit
Power Supply Voltage	VCC	2.5	18	V
Operating Temperature Range	TA	-40	105	°C

## Electrical Characteristics

( $V_{CC}=5V$ ,  $T_A=25^{\circ}C$ , unless otherwise specified.)

Parameter	Symbol	Conditions	Min	Typ	Max	Unit
<b>TOTAL CURRENT CONSUMPTION</b>						
Total Supply Current Not Including the Output Sinking Current	ICC	TA=25°C		0.5	1	mA
		-40°C<TA<105°C		0.6		
<b>VOLTAGE CONTROL LOOP</b>						
Transconduction Gain (VCTRL). Sink Current Only	Gmv	TA=25°C	1	3.5		mA/mV
		-40°C<TA< 105°C		2.5		
Voltage Control Loop Reference	VREF	TA=25°C	1.198	1.21	1.222	V
		-40°C<TA< 105°C	1.186		1.234	
Input Bias Current (VCTRL)	IIBV	TA=25°C		50		nA
		-40°C<TA< 105°C		100		
<b>CURRENT CONTROL LOOP</b>						
Transconduction Gain (ICTRL). Sink Current Only	Gmi	TA=25°C	1.5	7		mA/mV
Current Control Loop Reference	VSENSE	IOUT=2.5mA, TA=25°C	196	200	204	mV
		IOUT=2.5mA, -40°C <TA< 105°C	190		210	
Current Out of Pin ICTRL at 200mV	IIBI	TA=25°C		25		µA
		-40°C<TA< 105°C		50		
<b>OUTPUT STAGE</b>						
Low Output Voltage at 10mA Sinking Current	VOL	TA=25°C		200		mV
Output Short Circuit Current. Output to VCC, Sink Current Only	IOS	TA=25°C		27	50	mA
		-40°C<TA< 105°C		35		

# MB3307

## Typical Performance Characteristics

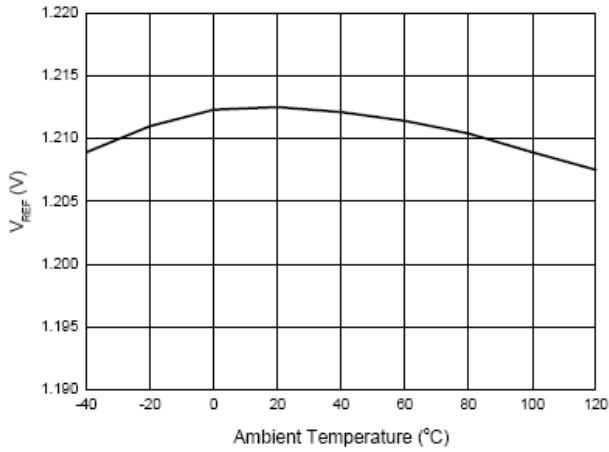

Figure 5:  $V_{REF}$  vs. Ambient Temperature

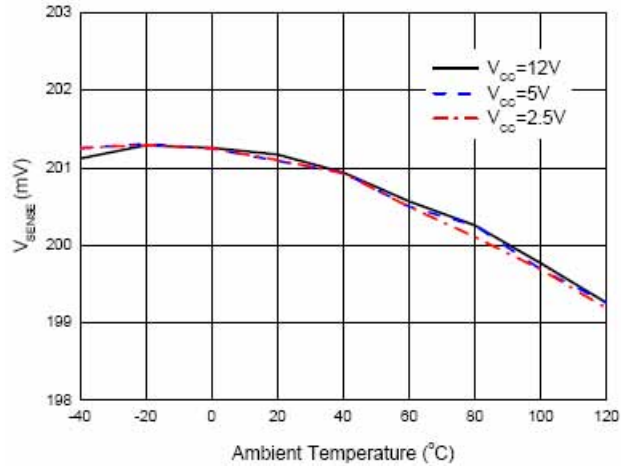

Figure 6:  $V_{SENSE}$  vs. Ambient Temperature

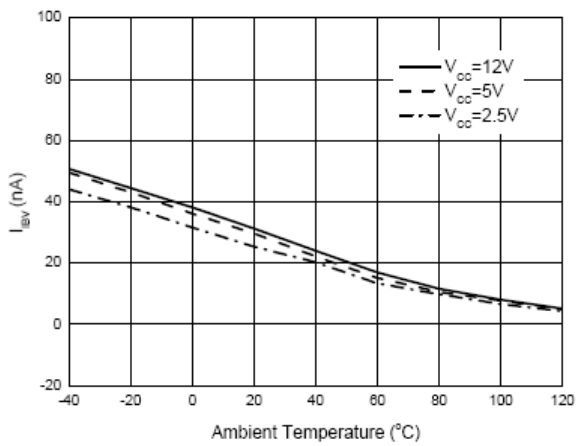

Figure 7:  $I_{IBV}$  vs. Ambient Temperature

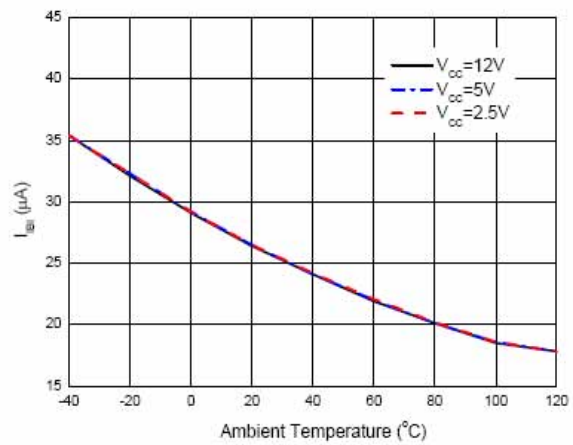

Figure 8:  $I_{IBI}$  vs. Ambient Temperature

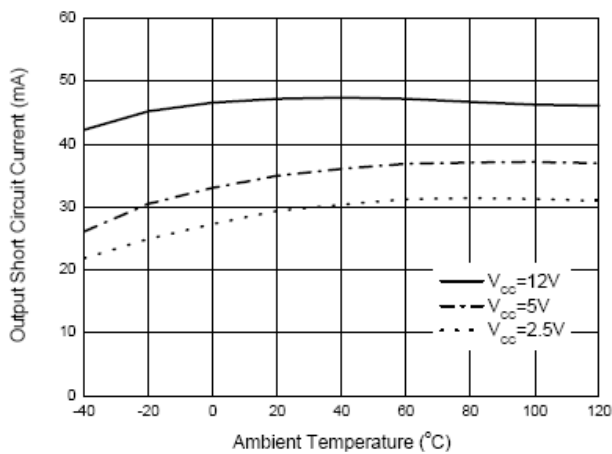

Figure 9: Output Short Circuit Current vs. Ambient Temperature

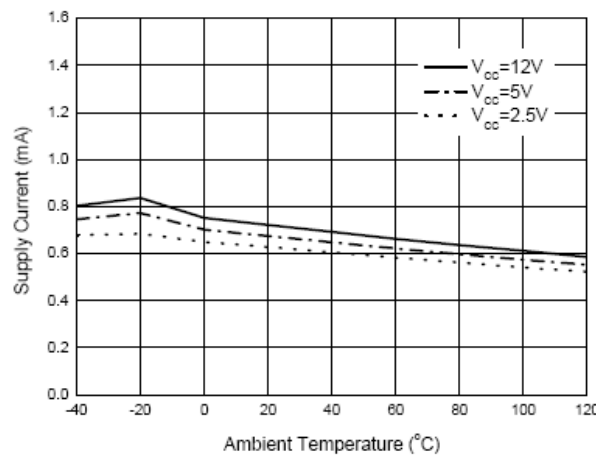

Figure 10: Supply Current vs. Ambient Temperature

# MB3307

## Mechanical Dimensions

SOT-23-6

Unit: mm(inch)

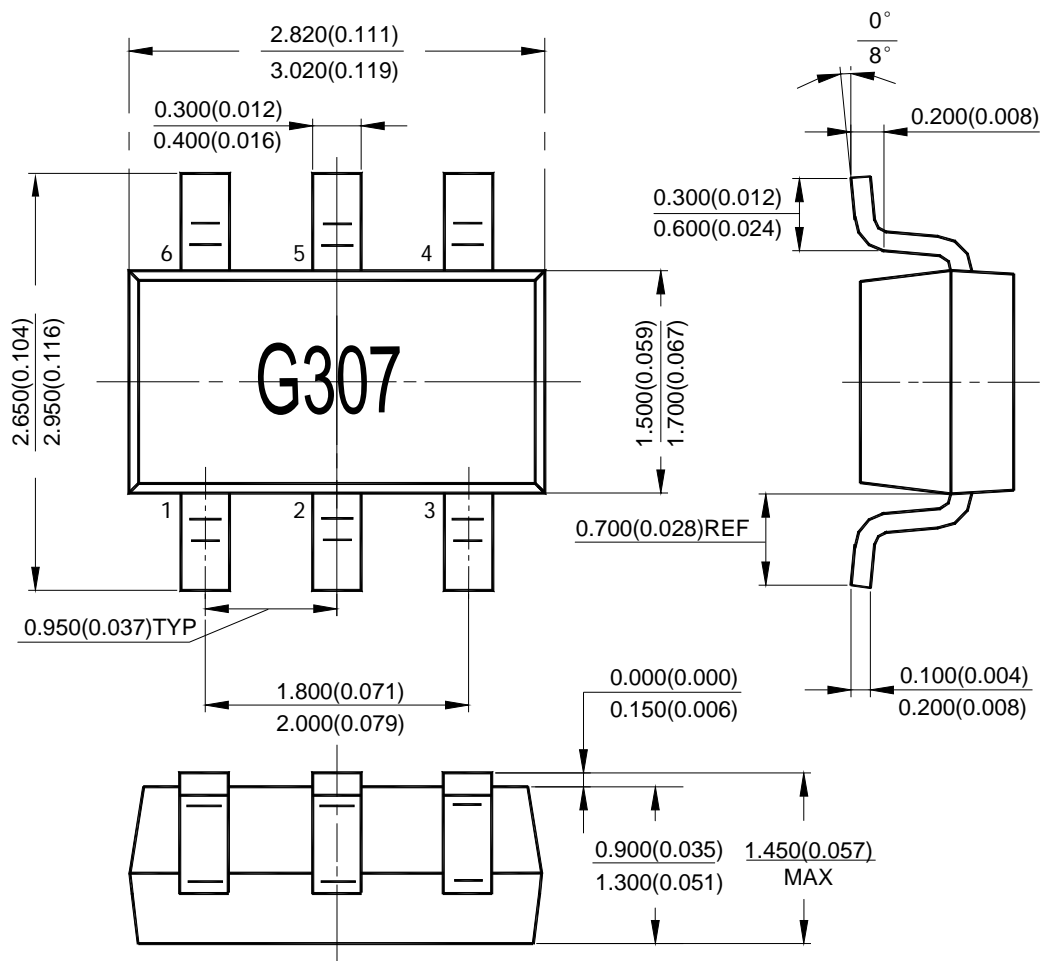

# MB3307

## IMPORTANT NOTICE

**CBC Microelectronics Co., LTD reserves the right to make changes without further notice to any products or specifications herein. CBC Microelectronics Co., LTD does not assume any responsibility for use of any its products for any particular purpose, nor does CBC Microelectronics Co., LTD assume any liability arising out of the application or use of any its products or circuits. CBC Microelectronics Co., LTD does not convey any license under its patent rights or other rights nor the rights of others.**